

90th Anniversary of the Department of Physical Chemistry of the University of Sofia  
Юбилей: 90 години на Катедрата по физикохимия на Софийския университет



## WETTING BEHAVIOR OF A NATURAL AND A SYNTHETIC THERAPEUTIC PULMONARY SURFACTANTS

<sup>1</sup>Lidia Alexandrova, <sup>2</sup>Michail Nedyalkov, <sup>2</sup>Dimo Platikanov  
<sup>1</sup>Institute of Physical Chemistry, Bulgarian Academy of Sciences  
<sup>2</sup>University of Sofia

**Abstract.** The wetting properties of aqueous solutions of two therapeutic pulmonary surfactants (TPS) with respect to solid surfaces with different degree of hydrophobicity  $\theta_w$  have been studied. A special procedure for hydrophobization of the SiO<sub>2</sub>-glass hydrophilic surface allows the preparation of hydrophobic solid surfaces with different  $\theta_w$ . The contact angles of drops from a TPS solution onto SiO<sub>2</sub>-glass surfaces have been measured as a function of their  $\theta_w$ . The completely hydrophilic SiO<sub>2</sub>-glass surface is essentially hydrophobized by the animal-derived TPS *Curosurf* as well as by the synthetic TPS *CHF 5633*. The hydrophobization depends on the surfactant concentration - the contact angles increase with increasing the *Curosurf* concentration *C* in the low concentration range, but they remain almost constant in a wide range of  $C > 90 \mu\text{g/ml}$ . Similar are the  $\theta(\theta_w)$  curves for aqueous solutions of both TPS. The thickness *h* of the wetting thin liquid films from aqueous solutions of *Curosurf* as well as of *CHF 5633* on SiO<sub>2</sub>-glass surfaces depends on  $\theta_w$  of the solid surface. The  $h(\theta_w)$

curves always pass a minimum. The  $h$ -values, as well as the  $h(\theta_w)$  curve, are mainly determined by the balance of the positive (repulsive) steric and negative (attractive) hydrophobic disjoining pressures, which depend on the orientations and conformations of the molecules adsorbed on the wetting film surfaces from the very complicated multi-component aqueous solutions. Practically no significant difference in the wetting behaviour of the aqueous solutions of the natural TPS *Curosurf* and the synthetic TPS *CHF 5633* has been established, however about 25% less *Curosurf* than *CHF 5633* was needed to achieve almost the same wetting behaviour.

*Keywords:* pulmonary surfactant, therapeutic surfactant preparation, wetting behavior, contact angle, wetting liquid film

## Introduction

The pulmonary surfactant system has proven to be of crucial importance to breathing. Pulmonary surfactant deficiency, dysfunction, or inactivation can lead to development of the respiratory distress syndrome (RDS), an important cause of perinatal mortality of premature newborns (Kramer, 2007). The treatment of such newborns with animal derived therapeutic pulmonary surfactant preparations has been shown to be very useful, in most cases being a decisive factor for survival of the premature infants (Zuo et al., 2008). Pulmonary surfactant dysfunction also contributes to other disease of the lungs.

Many observations show that the breathing function can be strongly affected by air pollution –fine and ultrafine particles from the atmospheric air can be conducted to the air spaces of the lung. However, the interaction of the particles in air with the pulmonary surfactant layers in the alveoli (Yang et al., 2008) is still not sufficiently studied. Several studies on the effects of nanoparticles from different substances on the pulmonary surfactant function have been published recently.

There are only few data about the wetting properties of the solid surfaces involved. In Davis et al. (2009) the forces of adhesion between micronised budesonide particles and simulated *Survanta* monolayers have been studied, but also the contact angles  $\theta$  of a microdrop of pure water placed onto the surface of a compacted budesonide have been measured. The data confirmed that the budesonide surface is hydrophobic ( $\theta \approx 48^\circ$ ) and the *Survanta* layers at increasing surface pressure exhibit a rising hydrophobic character.

In the present paper we turn our attention to the wetting properties of therapeutic pulmonary surfactant aqueous solutions with respect to solid surfaces with different degree of hydrophobicity. The contact angles of drops from a pulmonary surfactant solution (or respectively from pure water) onto differently hydrophobic  $\text{SiO}_2$  glass

surfaces, as well as the film thickness of wetting films from the same solutions onto the same solid surfaces, have been measured depending on the degree of hydrophobicity of these surfaces. We studied the wetting contact angles as well as the film thickness of wetting thin liquid films on solid surface from aqueous solutions of the natural therapeutic pulmonary surfactant *Curosurf* and the synthetic one *CHF5633*.

### **Materials and methods**

#### *Therapeutic pulmonary surfactant aqueous solutions*

The therapeutic pulmonary surfactants studied were the animal-derived preparation *Curosurf* and the synthetic preparation *CHF5633*, produced by *Chiesi Farmaceutici, Parma, Italy*. The *Curosurf* preparation has been isolated from swine lungs through extraction with organic solvents and further purified via liquid-gel chromatography (Robertson et al., 1990). *Curosurf* contains polar phospholipids and hydrophobic surfactant specific low molecular proteins (SP-B and SP-C). *CHF5633* contains 1,2 dipalmitoyl phosphatidylcholine (DPPC) + Palmitoyl oleoyl phosphatidyl glycerol (POPG) and the hydrophobic specific proteins synthetic analogues SP-B and SP-C. The therapeutic preparations are suspended in 0.15 M NaCl up to concentration of 80 mg/ml. We have diluted this preparation with 0.15 M NaCl up to the surfactant concentration required for a single experiment. The NaCl, suprapur from Merck, Germany, was roasted at 560°C to omit all surface active impurities. Tri-distilled water was used for all solutions.

#### *The solid surfaces*

The solid substrates used in all experiments were SiO<sub>2</sub>-glass smooth, flat plates. The well polished glass surface was very carefully washed with acid mixtures and rinsed several times with doubly distilled water. Thereby a substrate with a completely hydrophilic surface was obtained. A special procedure for hydrophobization of this hydrophilic surface allows the preparation of hydrophobic glass surfaces with different degree of hydrophobicity  $\theta_w$ . As a measure for the degree of hydrophobicity we have used the contact angle  $\theta_w$  of a drop of tri-distilled water on this surface.

(i) Hydrophobization of the surface: the pure glass plate was immersed in a 25% solution of trimethylchlorosilane in dichloromethane for 12 hours, the first 10 min being in a ultrasonic bath. The plate was removed from the solution, rinsed several times with dichloromethane and finally dried in a oven at 95°C. Thus a degree of hydrophobicity, i.e. contact angle  $\theta_w = 90^\circ$ , has been obtained.

(ii) Changing the degree of hydrophobicity  $\theta_w$ : hydrophobic glass surfaces with less degree of hydrophobicity were obtained by treating the surface ( $\theta_w = 90^\circ$ ) with bichromate sulfuric acid mixture in a ultrasonic bath. The degree of hydrophobicity  $\theta_w$  decreases with time of treatment. The longer treatment of the plate as well as the higher concentration of the acid mixture determines a lower degree of hydrophobicity  $\theta_w$ . Finally the glass plate was carefully rinsed several times with doubly distilled water. In such a way solid surfaces with  $\theta_w$ -values in the range from  $0^\circ$  to  $90^\circ$  have been obtained.

#### *Thickness of wetting liquid films measurements*

The investigation of thin liquid wetting films on solid surface has been performed using a special experimental cell (Platikanov, 1964; Zorin et al., 1987; Diakova et al., 2002) shown in Fig. 1. The films are formed between the horizontal surface **6** of the  $\text{SiO}_2$  glass plate and the hemispherical meniscus aqueous solution/air **5**, which is coming out from the orifice of a vertical capillary tube **3** towards the solid surface. The meniscus is put very close to it, using a micro-metric syringe which creates a pressure difference between the gas phase in the capillary tube and the liquid phase **4** in the teflon vessel **2**. The thickness  $h$  of the wetting films is measured interferometrically. The microscopic circular films are observed in reflected monochromatic light through the transparent bottom of the cell using a vertical microscope **1**. The light reflected from the film is measured using a photometric device with amplifier and the dependence photocurrent/time is recorded and further processed by a computer, which calculates the thickness  $h$  of the microscopic thin liquid film.

#### *Contact angle measurements*

The contact angle  $\theta$  at the three phase contact line solid/liquid/gas was measured using the sessile drop technique [9] that is suitable for the flat  $\text{SiO}_2$ -glass plate. This plate is covered by a glass cuvette with plane-parallel optical walls in order to obtain a saturated vapour. A micro-drop (volume of  $0.5 \mu\text{l}$ ) is placed on the solid surface using a micro-pipette. The sessile drop is illuminated using white diffuse light and it is observed using a tele-microscope. A powerful objective produces a clear image of the drop profile which is directly transferred through a CCD-camera and analysed using the special computer program *IMAQ Vision Builder* for image analysis. The contact angle solid/liquid/gas is determined from the tangent to the drop at the three phase contact line. The accuracy of the contact angle measurements is  $\pm 0.3^\circ$  in the range of  $1^\circ$ - $5^\circ$ ,  $\pm 1.0^\circ$  in the range of  $5^\circ$ - $20^\circ$ , and  $\pm 1.5^\circ$  in the range of  $75^\circ$ - $100^\circ$ .

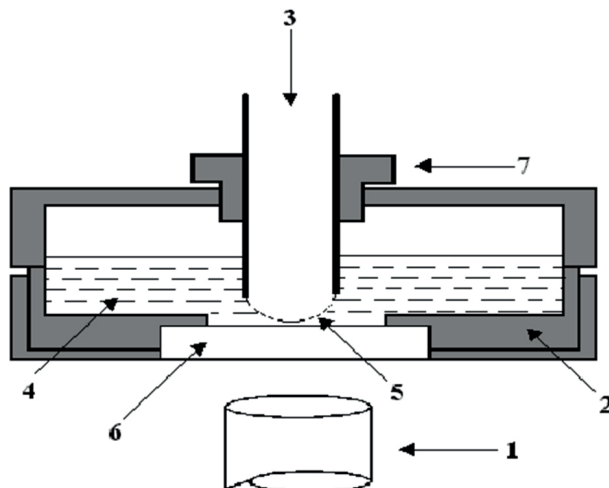
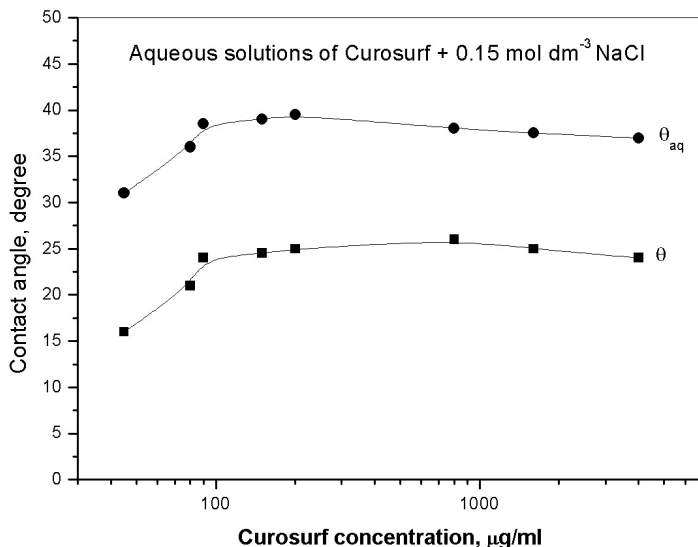

**Fig. 1.** Cell for investigation of microscopic wetting thin liquid films. 1 - microscope, 2 - teflon vessel, 3 - vertical capillary tube, 4 - liquid phase (aqueous solution), 5 - hemispherical meniscus, 6 - solid substrate ( $\text{SiO}_2$ -glass plate), 7 - teflon ring

Two procedures of measurement of contact angle have been applied and, respectively, different values for a given system have been measured by each of these procedures. The respective values are denoted as follows:  $\theta_{\text{aq}}$  - the contact angle at the three phase contact line of a drop of tri-distilled water placed on the solid surface;  $\theta$  - the contact angle for a drop of pulmonary surfactant solution placed on the solid surface. It should be noted that the contact angles of a water drop  $\theta_{\text{aq}}$  and  $\theta_{\text{w}}$  should not be mixed up: the value of  $\theta_{\text{aq}}$  reflects the wetting properties of the pulmonary surfactant studied, while the value of  $\theta_{\text{w}}$  is a measure for the degree of hydrophobicity of the solid surface only and it has nothing to do with the pulmonary surfactant.

Procedure (a): A  $0.5 \mu\text{l}$  drop of tri-distilled water placed on the pure  $\text{SiO}_2$ -glass surface completely spreads giving a zero contact angle ( $\theta_{\text{aq}} = 0^\circ$ ), since the solid surface is fully hydrophilic. However when the drop contains aqueous solution of therapeutic pulmonary surfactant, it does not completely spread on the hydrophilic solid surface and a contact angle  $\theta > 0^\circ$  can be measured. Initially this contact angle decreases with time, because of slow spreading of the liquid in the drop, and becomes constant after about 5 minutes. In all experiments the  $\theta$ -values have been measured 15 minutes after placing the drop of pulmonary surfactant solution on the given  $\text{SiO}_2$ -glass plate.

Procedure (b): Another identical, pure  $\text{SiO}_2$ -glass plate was immersed for a definite time into the aqueous solution of therapeutic pulmonary surfactant under investigation. After the treatment with pulmonary surfactant solution the solid surface has been dried. The contact angle of a  $0.5 \mu\text{l}$  drop pure water measured immediately thereafter was  $\theta_{\text{aq}} > 0^\circ$ . Hence the pretreatment of the hydrophilic solid surface with pulmonary surfactant solution hydrophobizes this surface. Again the contact angle  $\theta_{\text{aq}}$  decreases with time and attains a constant value after ca.15 minutes. The longer duration of pretreatment of the solid surface with pulmonary surfactant solution corresponds to larger contact angles. However, the  $\theta_{\text{aq}}$ -values remain constant after pretreatment time of ca.15 minutes. Hence, all measurements were carried out after 15 min from placing the water-drop on the solid surface, the time of its pretreatment (i.e. the time of contact between the glass plate and the solution under investigation) being 30 minutes.



**Fig. 2.** Dependence of the contact angles  $\theta$  of a drop of *Curosurf* solution and  $\theta_{\text{aq}}$  of a drop of pure water on the concentration of the *Curosurf* aqueous solution

### Experimental results

#### *Dependence of the $\theta$ and $\theta_{\text{aq}}$ values on the concentration of the Curosurf solution*

Systematic measurements of the contact angles  $\theta$  (according to procedure (a)) and  $\theta_{\text{aq}}$  (according to procedure (b)) have been carried out with aqueous solutions (concentrations in the range from  $40 \mu\text{g/ml}$  to  $4 \text{ mg/ml}$ ) of *Curosurf*, containing 0.15

M NaCl. Each value was obtained from 10 single measurements. The results presented in Fig. 2 clearly show that: (i) The aqueous solutions of *Curosurf* hydrophobize the pure hydrophilic SiO<sub>2</sub>-glass surface – both  $\theta$  and  $\theta_{\text{aq}}$  are larger than zero in the whole concentration range; (ii) Both contact angles  $\theta$  and  $\theta_{\text{aq}}$  increase with increasing the *Curosurf* concentration  $C$  in the low concentration range. The values of the contact angles reach a maximum at  $C \approx 200 \mu\text{g/ml}$  and remain almost constant in a wide range of  $C > 90 \mu\text{g/ml}$ ; (iii) The values of  $\theta_{\text{aq}}$  are essentially larger than those of  $\theta$ , due to the different procedures of their measurement; (iv) The two curves  $\theta_{\text{aq}}(C_s)$  and  $\theta(C_s)$  run practically parallel to each other in the whole concentration range studied.

These results confirm that the contact angles  $\theta$  and  $\theta_{\text{aq}}$  are reliable parameters for characterization of the hydrophobization of a hydrophilic solid surface by a solution of pulmonary surfactant, respectively characterization of the wetting behaviour of the aqueous pulmonary surfactant solutions.

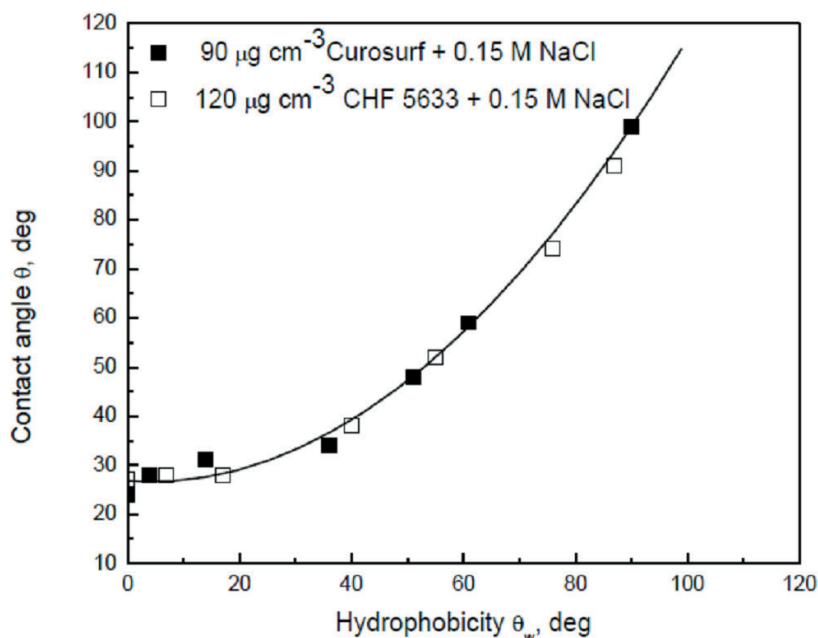
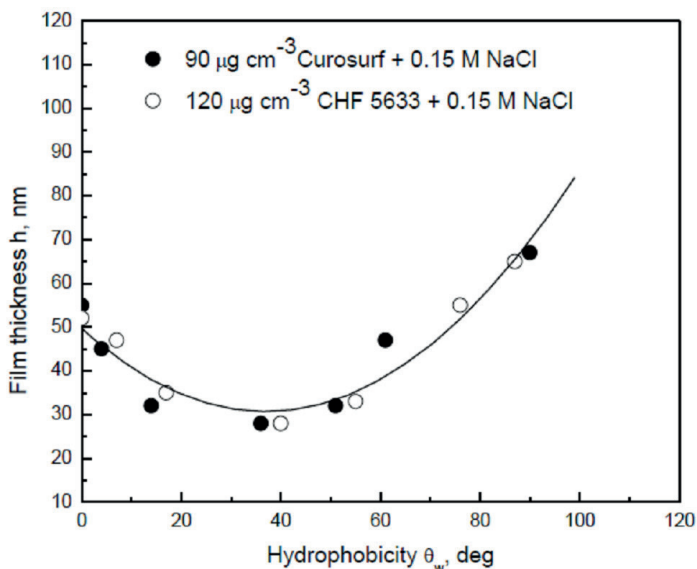

**Fig. 3.** Dependence of the contact angle  $\theta$  on the hydrophobicity  $\theta_w$  of the SiO<sub>2</sub>-glass surface for the two solutions: 90  $\mu\text{g/cm}^3$  *Curosurf* + 0.15M NaCl and 120  $\mu\text{g/cm}^3$  *CHF5633* + 0.15M NaCl

*Dependence of the  $\theta$  values for Curosurf and for CHF5633 aqueous solutions on the hydrophobicity of the solid surface*

The contact angles  $\theta$  at the three phase contact line  $\text{SiO}_2$ -surface / aqueous solution / air have also been measured for the two aqueous solutions:  $90 \mu\text{g}/\text{cm}^3$  Curosurf +  $0.15 \text{ mol}/\text{dm}^3$  NaCl as well as for  $120 \mu\text{g}/\text{cm}^3$  CHF 5633+  $0.15 \text{ mol}/\text{dm}^3$  NaCl. The dependences of  $\theta$  on the degree of hydrophobicity  $\theta_w$  of the solid surface are presented in Fig.3. The contact angles  $\theta$  naturally increase with increasing  $\theta_w$ . However the dependence  $\theta$  ( $\theta_w$ ) is not linear - the curve steepens at larger  $\theta_w$ -values. The  $\theta$  ( $\theta_w$ ) curves almost completely coincide for the two surfactants.

It is interesting that in all cases at low degrees of hydrophobicity ( $\theta_w$  in the range  $0^\circ - 30^\circ$ ) the measured contact angles  $\theta$  are larger than  $\theta_w$ , while in a wide range of degrees of hydrophobicity above  $\theta_w = 30^\circ$  the  $\theta$ -values are smaller than  $\theta_w$ .



**Fig. 4.** Dependence of equilibrium film thickness  $h$  on the hydrophobicity  $\theta_w$  of the  $\text{SiO}_2$ -glass surface for the two solutions:  $90 \mu\text{g}/\text{cm}^3$  Curosurf +  $0.15 \text{ M}$  NaCl and  $120 \mu\text{g}/\text{cm}^3$  CHF5633 +  $0.15 \text{ M}$  NaCl

*The thickness of wetting films from Curosurf and from CHF 5633 aqueous solutions*

Measurements of the equilibrium film thickness  $h$  have been carried out with thin liquid wetting films from  $90 \mu\text{g}/\text{cm}^3$  Curosurf +  $0.15 \text{ mol}/\text{dm}^3$  NaCl as well as from  $120 \mu\text{g}/\text{cm}^3$  CHF 5633 +  $0.15 \text{ mol}/\text{dm}^3$  NaCl aqueous solutions at different degrees of

hydrophobicity  $\theta_w$  of the  $\text{SiO}_2$ -glass surface. Fig. 4 presents the curves  $h(\theta_w)$  for both solutions. An interesting minimum at about  $\theta_w = 38^\circ$  in these curves has been obtained in both cases. It is clearly seen that both  $h(\theta_w)$  curves almost completely coincide for the two therapeutic pulmonary surfactants.

### Discussion and conclusions

The completely hydrophilic  $\text{SiO}_2$ -glass surface is essentially hydrophobized by the natural therapeutic pulmonary surfactant *Curosurf* as well as by the synthetic one *CHF 5633* ( $\theta \approx 25^\circ$  at  $\theta_w = 0^\circ$ ). The hydrophobization depends on the surfactant concentration - the contact angles  $\theta$  and  $\theta_{aq}$  increase with increasing the *Curosurf* concentration  $C$  in the low concentration range, but they remain almost constant in a wide range of  $C > 90$   $\mu\text{g/ml}$ .

The pretreatment of the pure  $\text{SiO}_2$ -glass surface with trimethylchlorosilane and consecutively with bichromate sulfuric acid mixture creates hydrophilic and hydrophobic patches on the solid surface. The total areas of these two types of patches determine the hydrophobicity  $\theta_w$  of the pretreated  $\text{SiO}_2$ -glass surface. At low degrees of hydrophobicity ( $\theta_w$  in the range  $0^\circ - 30^\circ$ ) the hydrophobization due to the pulmonary surfactant predominantly determines the contact angle  $\theta$ , while in a wide range of degrees of hydrophobicity above  $\theta_w = 30^\circ$  the hydrophobic patches of the surface predominate and the influence of the pulmonary surfactant could be just the opposite – it decreases the hydrophobicity of the solid/aqueous solution interface.

The thickness of the wetting thin liquid films from both therapeutic pulmonary surfactant aqueous solutions depends on the hydrophobicity  $\theta_w$  of the  $\text{SiO}_2$ -glass surface and the thickness - hydrophobicity curves always pass a minimum at  $\theta_w$  about  $30^\circ$ . The equilibrium thickness  $h$  is determined by the balance of all surface forces operative in the thin liquid wetting film: the Van der Waals disjoining pressure  $\Pi_{vw}$ , the electrostatic disjoining pressure  $\Pi_{el}$ , the structural disjoining pressure  $\Pi_{str}$ , the steric disjoining pressure  $\Pi_s$  (Derjaguin & Landau, 1941; Verwey & Overbeek, 1948; Izraelachvili, 1991; Churaev et al., 1987). At 0.15 M NaCl and relatively large  $h$ -values  $\Pi_{el}$  is rather low and  $\Pi_{vw}$  may be neglected. The attractive, hydrophobic  $\Pi_{str}$  and the repulsive  $\Pi_s$  mainly determine the thickness. Their values depend on the hydrophobic and hydrophilic patches of the solid surface as well as on the orientation and conformation of the adsorbed molecules of the phospholipids and the surfactant specific proteins. The therapeutic pulmonary surfactant aqueous solution is a very complicated multi-component system. The variety of components determines a variety of orientations and conformations of the adsorbed molecules. The minimum in the  $h$

( $\theta_w$ ) curves could be determined by competitive variation of the disjoining pressures  $\Pi_{str}$  and  $\Pi_s$  due to changes in the structure and thickness of the adsorption layers on the wetting film surfaces, including the orientation of the adsorbed molecules, at different hydrophobicity of the solid surface, i.e. at different areas of the hydrophobic and hydrophilic patches on this surface.

An important result is that practically no difference in the wetting behavior of the aqueous solutions of the natural therapeutic pulmonary surfactant *Curosurf*, and the synthetic one *CHF 5633* has been established. However the same  $h(\theta_w)$  and  $\theta(\theta_w)$  curves for both surfactants were obtained at concentrations  $90 \mu\text{g}/\text{cm}^3$  for the *Curosurf* and  $120 \mu\text{g}/\text{cm}^3$  for the *CHF 5633*, i.e. 25% less *Curosurf* than *CHF 5633* was needed to achieve the same wetting behavior.

**Acknowledgment.** The supply of free samples of the therapeutic pulmonary surfactant preparations by *Chiesi Farmaceutici, Parma, Italy* is acknowledged with gratitude.

## REFERENCES

- Churaev, N.V., Derjaguin, B.V. & Muller, V.M. (1987). *Surface forces*. New York: Springer
- Davies, M.J., Brindley, A., Chen, X., Doughty, S.W., Marlow, M. & Roberts, C.J. (2009). A quantitative assessment of inhaled drug particle - pulmonary surfactant interaction by atomic force microscopy. *Colloids Surf. B*, 73: 97-102.
- Derjaguin, B.V. & Landau, L.D. (1941). Theory of the stability of strongly charged lyophobic sols and of the adhesion of strongly charged particles in solutions of electrolytes. *Acta Physicochim. USSR*, 14 633-642.
- Diakova, B., Filiatre, C., Platikanov, D., Foissy, A. & Kaisheva, M. (2002). Thin wetting films from aqueous electrolyte solutions on SiC/Si wafer. *Adv. Colloid Interface Sci.* 96, 193-211.
- Israelachvili, J.N. (1991). *Intermolecular and surface forces*. New York: Academic Press.
- Kramer, B.W. (2007). The respiratory distress syndrome (RDS) in preterm infants: physiology, prophylaxis and new therapeutic approaches. *Intensivmed*, 44. 403-408.
- Lyklema, J. (2000). *Fundamentals of interface and colloid science; volume III: liquid-fluid interfaces*. London: Academic Press.
- Platikanov, D. (1964). Experimental investigation on the “dimpling” of thin liquid films. *J. Phys. Chem.*, 68, 3619-3624.

- Robertson, B., Curstedt, T., Johansson, J., Jornvall, H. & Kobayashi, T. (1990). Structural and functional characterization of porcine surfactant isolated by liquid gel chromatography (pp. 237-246). In: von Muller, W.P. (Ed.). *Progress in respiration research; volume 25*. Basel: Karger.
- Verwey, E.J.W. & Overbeek, J.T.G. (1948). *Theory of the stability of lyophobic colloids*. Amsterdam: Elsevier.
- Yang, W., Peters, J.I. & Williams 3rd, R.O. (2008). Inhaled nanoparticles - a current review. *Int. J. Pharm.* 356, 239-247.
- Zorin, Z., Platikanov, D. & Kolarov, T. (1987). Transition region between aqueous wetting films on quartz and the adjacent meniscus. *Colloid Surf. A*, 22, 147–155.
- Zuo, Y.Y., Veldhuizen, R.A., Neumann, A.W., Petersen, N.O. & Possmayer, F. (2008). Current perspectives in pulmonary surfactant—inhibition, enhancement and evaluation. *Biochim. Biophys. Acta*, 1778, 1947-1997.

✉ **Prof. Dr. D. Platikanov** (corresponding author)

Department of Physical Chemistry

University of Sofia

1, James Bourchier Blvd.

1164 Sofia, Bulgaria

E-mail: platikanov@chem.uni-sofia.bg