



Physics is an ever young science, Varna, October; 27 – 29, 2017
Физиката – вечно млада наука, Варна, 27 – 29 октомври 2017 г.

RHEOLOGICAL PROPERTIES OF BATTER FOR GLUTEN FREE BREAD

¹G. Zsivanovits, ¹D. Iserliyska, ¹M. Momchilova, ²M. Marudova

¹Food Research and Development Institute – Plovdiv

²University of Plovdiv

Abstract. Gluten free and not gluten free batters for bread were prepared from wheat, rice, chestnut, maize and sweet potato batters. The rheological parameters of different gluten free batters were analysed by texture analyser (relaxation and retardation test) and rotational viscometer (Herschel-Bulkley model). The traditional wheat bread batter was used in comparison like control. The aim of the study was to see the capability of texture analyser in the investigation of rheological properties of batter. The received parameters are useful in the description of the differences between the behaviours of the batters from different batters. Based on the parallel experiments the ingredients of gluten free batters can be optimized.

Keywords: texture; Herschel-Bulkley model gluten free bread batter relaxation and retardation characteristics

Introduction

Bread is one of the most popular and wide spread baked products in the world, but many persons have dietary wheat intolerance. The responsible pathogenic factor of this intolerance has been identified like the gliadin fraction of gluten (Sivaramakrishnan et

al., 2004). Therefore, the interest for gluten free products has been increased and it is necessary to utilize new raw materials for the baking industry (Lamsal et al., 2007). Gluten free raw materials with potential for using in bakery industry are for example rice, chestnut, maize and sweet potato batters. The bases of bread structure formation from starch in the absence of gluten were established. The gluten free batters have different hydration and physical properties (Marco & Rosell, 2008).

The overall elastoplastic deformation of batter and gluten can be explained by the theory of viscoelasticity. To study that theory, it is required to use retardation and relaxation experiments and to evaluate the curves based on rheological models. In the retardation experiments the applied stress is constant and the deformation in changing as a function of time. In the stress relaxation test a constant strain is applied and the stress required to maintain the deformation is monitored as a function of time. The received functions can be analyzed by rheological models. In these models the spring elements represented the ideal solid (pure elastic behavior) and the dashpots represented the ideal fluids with viscous behavior. The serial and parallel combinations of these two elements describe the ideal viscoelastic materials. The bread batter is not an ideal viscoelastic material therefore to analyze the curves it is necessary to use complex rheological models where Kelvin (retardation) and Maxwell (relaxation) elements can be combined in serial or parallel chains. The received results contain the distribution of retardation or relaxation time and the information about the viscosity of the fluid part. These distributions describe the behavior of the structures at the molecular level. In retardation tests the applied constant stress press the layers which can cause the break or compression of the bottom layers. The molecular weight of the batter affects the received viscosity and viscoelasticity parameters (Hernandez-Esterada et al., 2012). Based on the researchers' results the bread batter and the gluten show slowly relaxation time for good baking properties. For gluten, rapid relaxation times were achieved with smaller molecules and slowly with higher molecular weight. Based on parallel farinograf experiments the rapid relaxation times (T_1 and T_2 £ 50 s) are related to structure due to hydrogen and other noncovalent bonds. The farinograms show that batter formation by covalent bonds (such as disulfide bonds) is a function of mixing time. Relaxation times T_3 and higher T_i (> 50 s to 1000 s) can be measures of batter quality similar like shown by farinograms (Figuroa et al., 2013). That discussed data suggest that the Maxwell model elements describe mainly protein-like structures. The non-protein polymers such as pentosanes and β -glucans acts as plasticizers (viscous behavior) and dissipate stress (Figuroa et al., 2013).

The aim of the study was to see the capability of texture analyser in the investigation of rheological properties of batter. The received parameters are useful in the description of the differences between the behaviours of the batters from different batters.

Materials and methods

Bread batters: Gluten free and not gluten free batters for bread were prepared from commercial wheat, rice, chestnut, maize and sweet potato batters and distilled water (1:1).

The batters were leave for hydration, for three hours at 25 °C before the experiments.

The *batter viscosity* was measured by rotational viscometer HAAKE VT 550 (Germany). All the measurements were done at 25 °C using standard cone-cylinder geometry (10.65 mm diameter and 0.9 mm gap). The flow experiments were conducted under steady-shear conditions with shear rate ranging from 0.0123 to 1000 s⁻¹. The viscosity is determined in fifty points in this range, distributed in logarithmic scale. All the measurements were repeated 5 times. The experimental data were evaluated by Herschel–Bulkley equation (Demirkesen et al., 2010).

The textures of the batters were examined by texture analyser Stablemicrosystems TAXT2+ (UK). All experiments were done at 25 °C in retardation (stress holding in time) and relaxation (strain holding in time) mode using standard cylinder in cylinder (d1 = 30 mm h1 = 40 mm, m1 = 30 g, d2 = 25 mm) geometry. 2 kPa compression stress was obtained by 1 mms⁻¹ deformation speed and hold for 180 s and after that the caused deformation was hold for 180 s. All the measurements were repeated 5 times. The retardation curves were evaluated by generalized Kelvin model and for the relaxation curves, generalized Maxwell models were applied.

Results and discussion

The shear stress (τ) versus shear rate $\dot{\gamma}$ data for all batters formulations at 25 °C were fitted to the Herschel–Bulkley equation:

$$\tau = \tau_0 + K\dot{\gamma}^n \tag{1}$$

where τ is the shear stress (Pa), τ_0 is the yield stress (Pa), $\dot{\gamma}$ is the shear rate (s⁻¹), K is the consistency index (Pasⁿ), and n is the power-law index (Fig. 1).

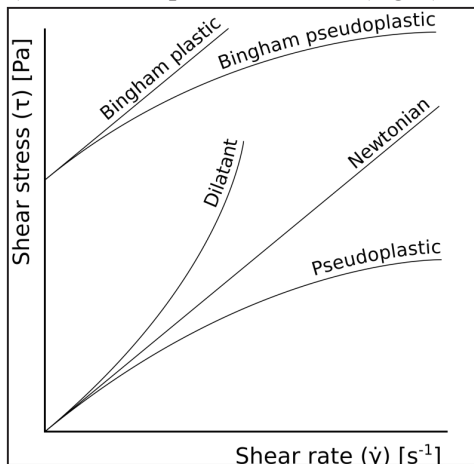

Figure 1. Shear stress (τ) versus shear rate of the materials

Table 1. Herschel-Bulkley model constants of the batter samples at 25 °C

Batter	t0 (Pa)	K (Pas ⁿ)	n	R ²
Wheat	16.12a	46.300c	0.600b	0.9990
Rice	736.10c	n.a.	n.a.	n.a.
Chestnut	605.88c	2.164a	0.926c	0.9864
Maize	433b	0.204a	1.000d	0.9859
Sweet potato	4.44a	33.652b	0.414a	0.9914

The wheat batter (control) and the sweet potato batter are characterized with very small values for the yield stress and with pronounced pseudoplastic behaviour ($n < 1$). For the pseudoplastic materials, as the shear stress increases the viscosity decreases as a result of the disruption of interactions between the components (Demirkesen et al., 2010; Hlaváč & Božiková, 2013) (Table 1).

The maize and chestnut batters are characterized with high values of the yield stress, which causes an anomaly at low shear rates. The viscosities of those batters remain constant when the shear rate increases and hence the batters are characterized as Bingham fluids.

The flow curve of rice batter samples could not be measured properly because when rice batter was used alone, the mixture was not stable enough and batter particles quickly precipitated (Demirkesen et al., 2010).

The *retardation curves* were analyzed by generalized Kelvin model (2 serial Kelvin elements – 6 parameters, Fig. 2):

$$\varepsilon(t) = \frac{\sigma_0}{E_0} + \frac{\sigma_0}{E_1} \cdot (1 - e^{-t/\lambda_1}) + \frac{\sigma_0}{E_2} \cdot (1 - e^{-t/\lambda_2}) + \frac{\sigma_0}{\mu_0} \cdot t, \text{ and } \lambda_i = \frac{\mu_i}{E_i} \quad (2)$$

where ε is the relative deformation, s is the stress, E is the elastic modulus (Pa), λ is the retardation time (s), m is the viscosity coefficient (Pas) and t is the loading time (s).

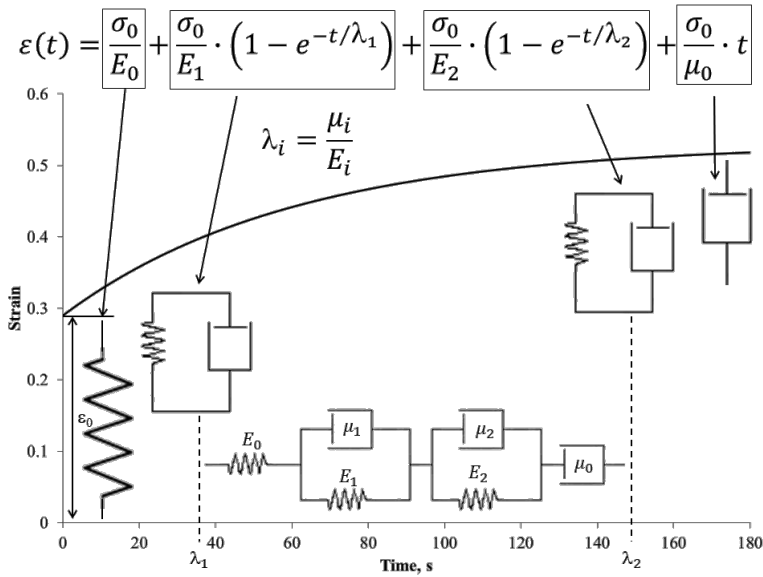

Figure 2. Creep retardation curve of batter with regressed equation and rheological model (s=stress, t=time, E=elastic modulus, m=viscosity coefficient, l=retardation time)

The retardation curve of wheat batter is characterized with lowest elasticity and the slowest first retardation component. All of the gluten free batters had higher elasticity during lower retardation time. Sweet potato batters showed the highest elasticity moduli. The first retardation time was smallest for sweet potato chestnut and maize batters, medium for rice and the highest for wheat. That may show the molecular weight distribution of the batters – the wheat has the weakest H bonds, which can be act of the presence of gluten (Bockstaele et al., 2011; Figueroa et al., 2013) (Table 2).

Table 2. Generalized Kelvin model Constants of the batter samples at 25 °C

Batter	E ₀ kPa	E ₁ kPa	λ ₁ s	E ₂ kPa	λ ₂ s	μ ₀ MPas	μ ₁ MPas	μ ₀ MPas	R ²
Wheat	38.48d	98.32c	10.12a	0.94c	1772.9b	1.87b	1.00c	1.67a	0.998
Rice	19.23b	82.62b	9.04a	0.94c	2697.4c	2.74c	0.75b	2.53c	0.994
Chestnut	28.34c	30.03a	18.27b	0.88b	1285.6a	1.44ab	0.54a	1.13d	0.999
Maize	6.41a	19.23a	30.12c	0.35a	1236.7a	1.12a	0.55a	0.43b	0.999
Sweet potato	60.18e	174.54d	8.94a	0.95c	2687.1c	2.73c	1.56d	2.54d	0.998

The relaxation curves were evaluated by generalized Maxwell model (3 parallel Maxwell elements – 7 parameters, Fig. 3):

$$\sigma(t) = \sigma_1 e^{-t/\tau_1} + \sigma_2 e^{-t/\tau_2} + \sigma_3 e^{-t/\tau_3} + \sigma_0, \text{ and } \tau_i = \frac{\eta_i}{\sigma_i} \quad (3)$$

where σ is the relaxation stress (Pa), T is the relaxation time, h is the viscosity coefficient and t is the deformation holding time (s).

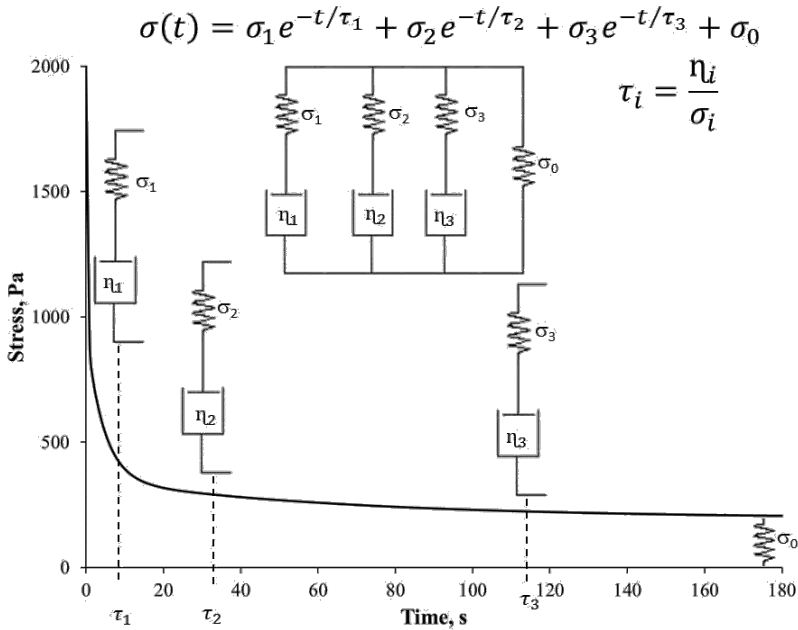

Figure 3. Stress relaxation curve of batter with regressed equation and rheological model (s=stress, t=time, h=viscosity, t=relaxation time)

Based on our data all of the batters have a very fast-relaxed component ($T_1 < 0.3$ s), the next component has less than 5 s where the wheat has the highest relaxation time, which is different from the others. These relaxation times are related to noncovalent bonds. The third relaxation time is the smallest for chestnut batter, a bit higher and very similar for sweet potato and wheat batters, more than two times more for maize batter and three times more for rice batter. The elasticity modulus at T_1 relaxation time is the smallest for the wheat batter, higher and more or less similar for the rice maize and sweet potato batters and the highest for

the chestnut batter. At T_2 relaxation time the elasticity modulus is the smallest for chestnut batter, almost 2 times more and very similar for rice maize and sweet potato batters and the highest for wheat batter. At T_3 relaxation time is the smallest and chestnut batters follows by maize and rice batter and the highest for wheat batter. The σ_0 is very similar for rice, sweet potato, maize and chestnut batters and much higher for the wheat batter. The first viscosity component is the highest for wheat and very similar for the other batters. At the second viscosity component the chestnut is the highest and different from the others. The third one is the smallest for the wheat and much higher and similar for the other batters. These results may show the effect of gluten and higher viscosity of the wheat batter which is coming from the weaker non-covalent bonds. The higher elasticity of the gluten free probes is the result of stronger covalent bonds, which is known from the literature (Figueroa et al., 2013; Peressini et al., 2016; Mita & Bohlin, 1983; Li et al., 2003) (Table 3).

Table 3. Generalized Maxwell model Constants of the batter samples at 25 °C

Batter	E_1 kPa	λ_1 s	E_2 kPa	λ_2 s	E_3 kPa	λ_3 s	E_0 kPa	μ_1 mPas	μ_2 mPas	μ_3 Pas	r^2
Wheat	1.08a	0.28c	0.60c	4.46b	0.19d	63.69a	0.16b	0.26d	7.46b	0.35a	0.998
Rice	1.45b	0.28bc	0.42b	2.86a	0.05c	192.54c	0.03a	0.19c	6.87ab	3.36c	0.999
Chestnut	1.72c	0.24a	0.25a	2.80a	0.02a	40.19a	0.03a	0.14a	9.22c	2.21b	0.999
Maize	1.51b	0.26abc	0.43b	2.92a	0.04b	147.70b	0.03a	0.17bc	6.77ab	3.76c	0.998
Sweet potato	1.52b	0.25ab	0.47b	2.76a	0.02a	56.64a	0.03a	0.16ab	5.90a	2.65b	0.999

Conclusions

The retardation and relaxation dependences show differences between the wheat batter (gluten) and other, gluten free batters. The parameters are capable to describe the batter forming and bread making behaviours of the gluten free batters.

Acknowledgement. The authors thank to the project of the Agricultural Academy of Bulgaria: HTAI 142 “Use of gluten free batter combination for bread making”.

REFERENCES

- Demirkesen, I., Mert, B., Sumnu, G., & Sahin, S. (2010). Utilization of chestnut flour in gluten-free bread formulations. *J. Food Eng.*, 101, 329 – 336.

- Figueroa, J.D.C., Hernández, Z.J.E., Véles, M.J.J., Rayas-Duarte, P., Martínez-Flores, H.E. & Ponce-García, N. (2011). Evaluation of degree of elasticity and other mechanical properties of wheat kernels. *Cereal Chem.*, 88, 12 – 18.
- Hernández-Estrada, Z.J., Figueroa, J.D.C., Rayas-Duarte, P. & Peña, R.J. (2012) Viscoelastic characterization of glutenins in wheat kernels measured by creep tests. *J. Food Eng.* 113, 19 – 26.
- Hlaváč, P. & Božiková, M. (2013). Effect of temperature and used ingredients on rheological parameters of pancake dough. *Acta Technologica Agriculturae*, 16(3), 63 – 66.
- Lamsal, B.P., Koegel, R.G. & Gunasekaran, S. (2007). Some physicochemical and functional properties of alfalfa soluble leaf proteins. *Food Sci. & Tech.*, 40, 1520 – 1526.
- Li, W., Dobraszczyk, B.J. & Schofield, J.D. (2003). Stress relaxation behavior of wheat dough, gluten, and gluten protein fractions. *Cereal Chem.*, 80, 333 – 338.
- Marco, C. & Rosell, C.M. (2008). Breadmaking performance of protein enriched, gluten-free breads. *Eur. Food Res. & Tech.*, 227, 1205 – 1213.
- Mita, T. & Bohlin, L. (1983). Shear stress relaxation of chemically modified gluten. *Cereal Chem.*, 60, 93 – 97.
- Peressini, D., Braunstein, D., Page, J.H., Strybulevych, A., Lagazio, C. & Scanlon, M.G. (2017). Relation between ultrasonic properties, rheology and baking quality for bread doughs of widely differing formulation. *J. Sci. Food & Agric.*, 97, 2366 – 2374.
- Sivaramakrishnan, H.P., Senge, B. & Chattopadhyay, P.K. (2004). Rheological properties of rice dough for making rice bread. *J. Food Eng.*, 62, 37 – 45.
- Van Bockstaele F., De Leyn, I., Eeckhout, M. & Dewettinck, K. (2011). Non-linear creep-recovery measurements as a tool for evaluating the viscoelastic properties of wheat flour dough. *J. Food Eng.*, 107, 50 – 59.

✉ **Dr. Gabor Ivan Zsivanovits (corresponding author)**

Food Research and Development Institute
154, Vasil Aprilov Blvd.
4003 Plovdiv, Bulgaria
E-mail: g.zsivanovits@canri.org